



TPK-10-xxx/4+0/(S) Power supply system: TNS

Power Surge Protector Type 3 / Class III

Plug-in format

TPK-10-xxx is the range of devices for discharging induced transient overvoltages (Type 3 / Class III), in accordance with EN/IEC 61643-11. DIN rail plug-in format. Ability to discharge induced voltage surges (8/20 μ s). For very fine protection of sensitive equipment(1.2/50 μ s). Installation downstream of type 2 protection.

- Suitable as the final stage of protection in panels with Type 2 protection devices installed upstream. The residual voltage left downstream is less than for Type 1 or 2. They should be installed as close as possible to the equipment being protected.
- Discharge capacity with an 8/20 μ s waveform. I_{max}: 10 kA.
- Exclusive devices for TNS earthing systems.
- Exclusive devices which are compatible with Power Line Communication networks.
- Biconnect - two types of terminal: for rigid or flexible cable and for fork type comb busbar.
- Available with optional remote signalling.

Application AC/DC distribution
Power supplies
Industrial automation
Telecommunications
Motor controls systems
PLC applications
Power transfer equipment
HVAC applications
AC drives
UPS systems
Security systems
IT / Data centers
Medical equipment

Features/Benefits
Easy installation or retrofit
Din-rail mountable
Fail-safe /self-protected design
Remote indicator (optional) with 3 pin NO/NC contact
IP20 finger-safe design
Visual indicator
Small foot print

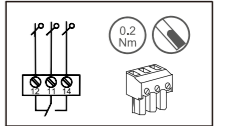

Data sheet

Type	TPK-10-xxx/4+0/(S)
Technical Data	
Power supply system	TNS
Maximum continuous voltage (U _c)	275 / 320 / 385 / 420V
SPD to EN 61643-11	Type 3
SPD to IEC 61643-11	class III
Nominal discharge current (8/20 μ s) (I _n)	5kA
Maximum discharge current (8/20 μ s) (I _{max})	10kA
Voltage protection level (U _p)	\leq 1.0 / 1.1/ 1.3 / 1.5kV
Response time (t _A)	< 25ns
Thermal Protection	YES
Operating State/Fault Indication	Green (good) / Red (replace)
Degree of protection	IP 20
Insulating material / flammability class	PA66,UL94 V-0
Temperature range	-40° C~+80° C
Altitude	13123 ft [4000m]
Conductor Cross Section (max)	35mm ² (Solid) / 25mm ² (Flexible)
Format	Pluggable
For mounting on	DIN rail 35mm
Place of installation	indoor installation
Remote Contacts (RC)	Optional
Type of remote signalling contact	changeover contact
Cross-sectional area for remote signalling terminals	max. 1.5 mm ² solid / flexible

Dimensions

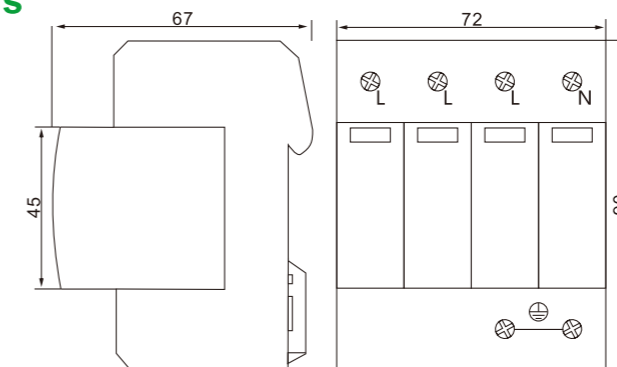

Internal configuration

